



STARSHIP

**Emergency Response Plan
University**

INTRODUCTION

Who we are

Starship is the world's leading autonomous robotic delivery company. Starship has operations in over 50 colleges and universities across the US with city level operations in countries including the US, Estonia, Finland, Germany, and the United Kingdom. We have made more than 7 million deliveries and travelled over 8 million miles.

Starship robots deliver food, drinks, and snacks from dining service providers, on-campus and nearby restaurants, to anyone on a campus with the Starship Food Delivery App on their mobile device.

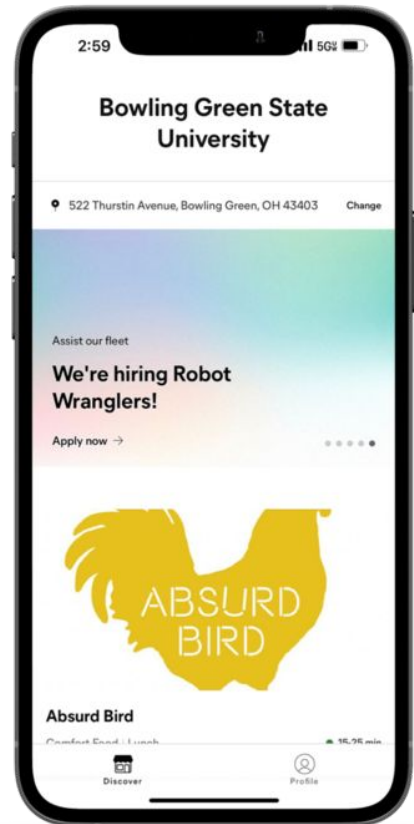

DIMENSIONS & TECH

- External dimensions: 697(L) x 569(W) x 1187(H) mm (height 571 mm without flagpole) (see more detailed info below Figure 1 and Figure 2)
- Unloaded weight (with flagpole, comm device and battery): 36.5 kg
- Cargo space dimensions: 400 x 340 x 305 mm
- Maximum cargo weight: 10 kg
- 12 cameras, 4 radars, 8 ultrasonic obstacle detectors, 360 degree coverage
- 2 Inertial Measurement Units, 1 GPS

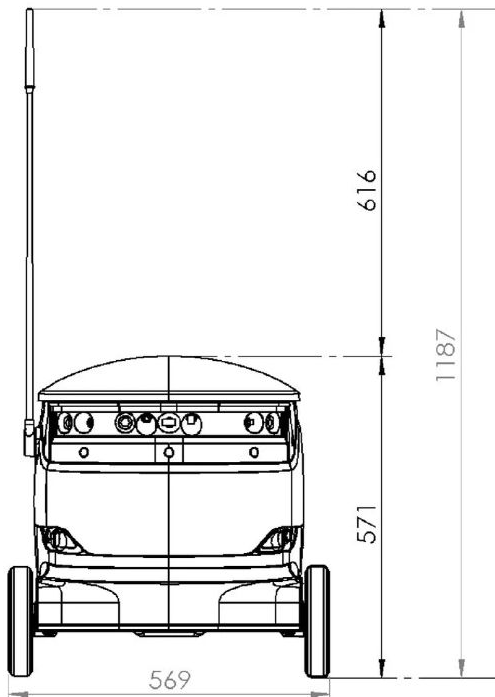

Figure 1: PDD Dimensions from the front

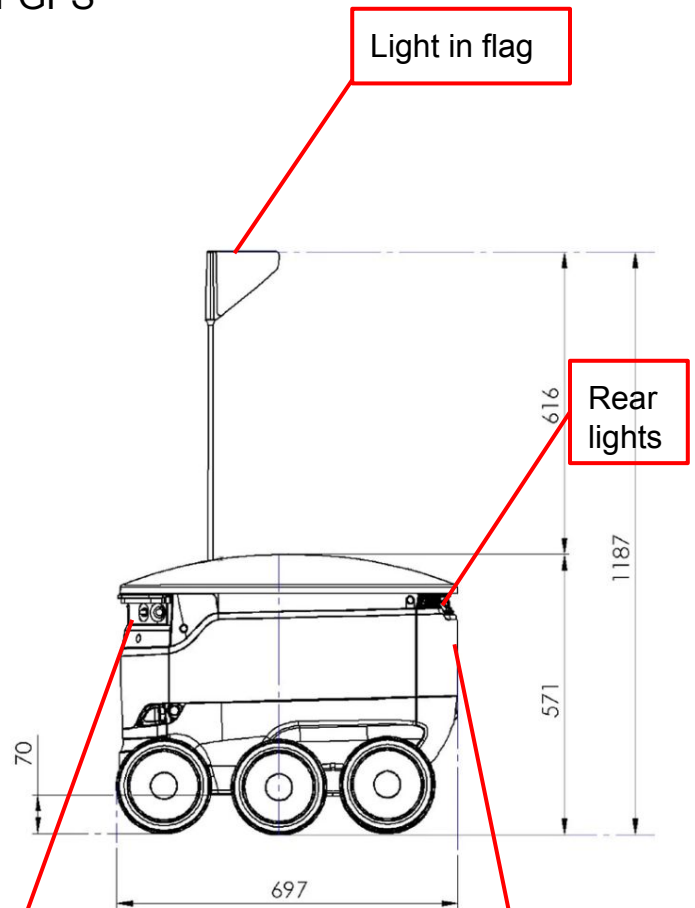
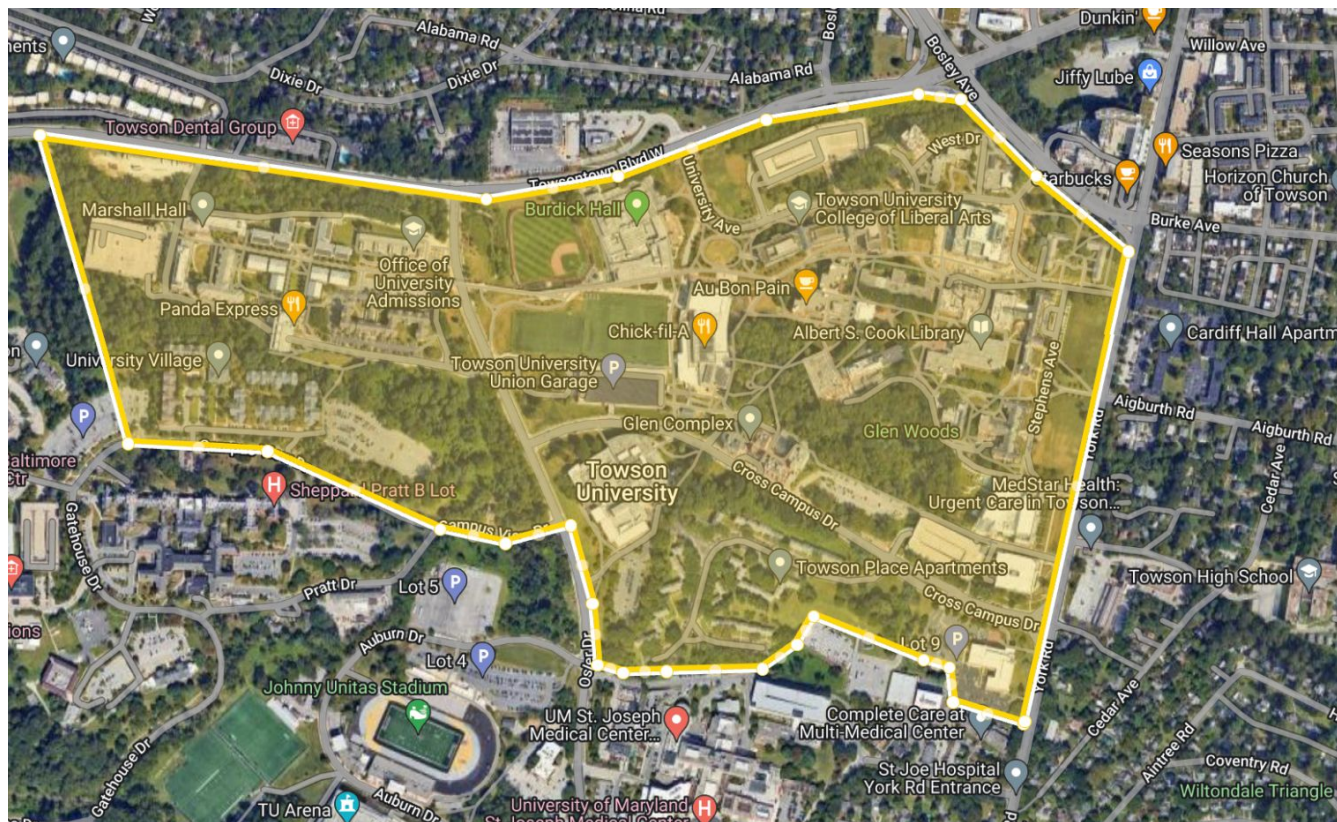

Figure 2: PDD Dimensions from side profile

OPERATIONS MAP



The service area in yellow represents all areas in which the Starship PDD will be able to access. Users can pin their location at various buildings and will be able to receive their order according to their pin.

1. How Starship robots operate

a) Where do the robots operate?

They operate in pedestrian areas and only use roads and cycle lanes for crossing.

b) Are Starship robots safe?

Absolutely! Safety is our priority.

Our robots are low-speed and low-weight. We have spent years developing our technology, testing it and improving it in real life environments.

Our robots have a 'bubble of awareness' and incredibly sophisticated obstacle avoidance technology that helps them to safely navigate around. They have numerous cameras, a sensor suite, radar, GPS and time-of-flight cameras.

All that tech means that they automatically avoid objects in their path and can tell how quickly objects around them are moving (or coming towards them). They're programmed to be risk averse – their main objective if there is anything near them is to slow down and get out of the way. Unlike humans who might see a car coming at a crossing and think '*I can make that if I run!*,' a robot won't take the chance – it will only move when it is absolutely safe to do so.

You can see how robots navigate on pavements in a short video we have produced. [Click here for the video](#) and [click here for the video with added audio description](#).

c) How do the robots know where to go and where not to go?

As mentioned above, there is lots of technology that helps our robots navigate, but our work starts long before the first robot navigates a campus.

Our robots are autonomous, but only within the confines set by humans – the robot can't suddenly decide it wants a trip to the beach!

Our mapping team drives every road in the area and records the layout. They look at data on traffic flow, where pedestrians walk (and whether one side of the pavement is busier than another); we look at crossings, traffic lights and drives. From there, we create a map for the robots, the robots can only use streets and crossings that we determine.

This work means that by the time the first delivery happens, we already have a good understanding of the campus and approved areas.

It also means that if there is a problem, we can be responsive to the local community.

d) What happens if there is a problem?

Every robot has human back-up. If a robot experiences a problem or encounters a situation it doesn't understand, it will let a human remote assistant know. The remote assistant can help the robot navigate the situation. If the situation is more serious, a local assistant will be notified to attend the scene. Both can disable the robot if necessary.

e) How does a robot safely cross a road?

Starship robots safely cross an estimated 150,000 roads and drives each day - that's 3 every second!

The robots only cross the road when it's safe to do so, using their sensors and machine learning to understand the environment around them to cross safely and efficiently.

Our robots will wait for the cross signal. The robots zoom in on the light display and wait for the appropriate cross light before crossing. If there is a problem or they are not sure about something, they have an audio recording that asks a passer by to press the button for them or they will let a remote assistant know they need a hand. They will always take a cautious approach.

You can see a video on road crossings [here](#).

f) How does a robot yield to emergency vehicles?

As mentioned earlier, our robots have a 'bubble of awareness' and incredibly sophisticated obstacle avoidance technology that helps them to safely navigate around. They have numerous cameras, a sensor suite, radar, GPS and time-of-flight cameras.

All that tech means that they automatically avoid objects in their path and can tell how quickly objects around them are moving (or coming towards them).

g) What type of fuel does Starship use?

Starship is all electric and the batteries are designed to comply with the following standards and safety regulations:

- UL 62133 – Safety requirements for portable batteries
- UN38.3 – Transportation safety regulation.
- IEC 62133-2:2017 - Li-ion battery safe design standard.
- IEC 61000-4 and EN 55032:2015/AC2016 EMC/EMI compliance.
- 2006/66/EU Battery Directive

g) What is the fire response procedure?

The Starship on-site team is trained in standard operating procedures in an event of a fire or risk of an event of a fire by utilizing fire extinguishers and alerting the appropriate authorities, if necessary.

Contact Information

For customer services, customers should use the customer services function within the **Starship App** on their mobile phones. The App is available in both the Apple App and Google Play Stores.

If you have any other questions please refer to our Company FAQs page at <https://www.starship.xyz/faqs/>. If you experience any issues or have any concerns about a robot you encounter please note the unique PDD identifier number on the side of the bot and email help@starship.xyz.

For any safety/risk related queries or incident reporting please contact safety@starship.co

Any law enforcement or emergency responder can reach out below in order of availability. They can also provide the safety@starship.co email to the claimant for direct contact.

Option 1: non-urgent please email safety@starship.co

Option 2: urgent: (844)782-7393

Option 3: urgent: Account Manager: (573)275-9624